



承 认 书

APPROVAL SHEET

客 户:

CUSTOMER: _____

品 名:

PARTNAME: _____ 铝电解电容器(E-CAP)

系 列:

SERIES: _____ AMZ 系列

规 格:

SPECIFICATION: _____ 见尺寸表

版本号:

VERSION: _____ QWH-18.001

日 期:

DATE: _____ 2018.02.07

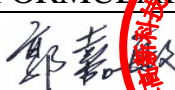
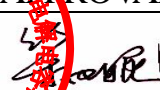
制 造 MANUFACTURE		客 户 CUSTOMER	
拟 制 FORMULATE	批 准 APPROVAL	检 验 CHECK	批 准 APPROVAL
 郭嘉敏	 李国良 技术部		

承认后请电子回签 please send back to Lhservice@china-fenghua.com
或发传真 or fax to 0758-2865650



序号 No	目 录 INDEX	页 page
1	概述 SCOPE	4
2	订货方式 HOW TO ORDER	4
3	主要特性表 MAIN SPECIFICATIONS	5
4	外形尺寸图 SHAPE AND DIMENSIONS	10
5	纹波电流频率因子 RIPPLE CURRENT FREQUENCY COEFFICIENT	11
6	尺寸表、允许纹波电流 DIMENSIONS AND RIPPLE CURRENT	12
7	包装 PACKING	13
8	贮存方法 STORAGE METHODS	14
9	其他说明 OTHERS	15



1. 概述 SCOPE

1.1 概述 SCOPE

本承认书规定了铝电解电容器的技术规范。

This specification contains descriptions of the quality of aluminum electrolytic capacitors.

1.2 参考标准 APPLICABLE SPECIFICATION

本承认书参考 JIS-C-5101-1 和 JIS-C-5101-4 制定。

This specification is made based on the Japanese Industrial Standard JIS-C-5101-1 Characteristics and JIS-C-5101-4.

1.3 工作温度范围 OPERATING TEMPERATURE RANGE

工作温度范围是电容器在施加额定工作电压条件下，可以长期可靠工作的环境温度范围。

Operating temperature range is the range of ambient temperature at which the capacitor can be operated continuously at rated voltage.

2. 订货方式 HOW TO ORDER

2.1 订货方式 HOW TO ORDER

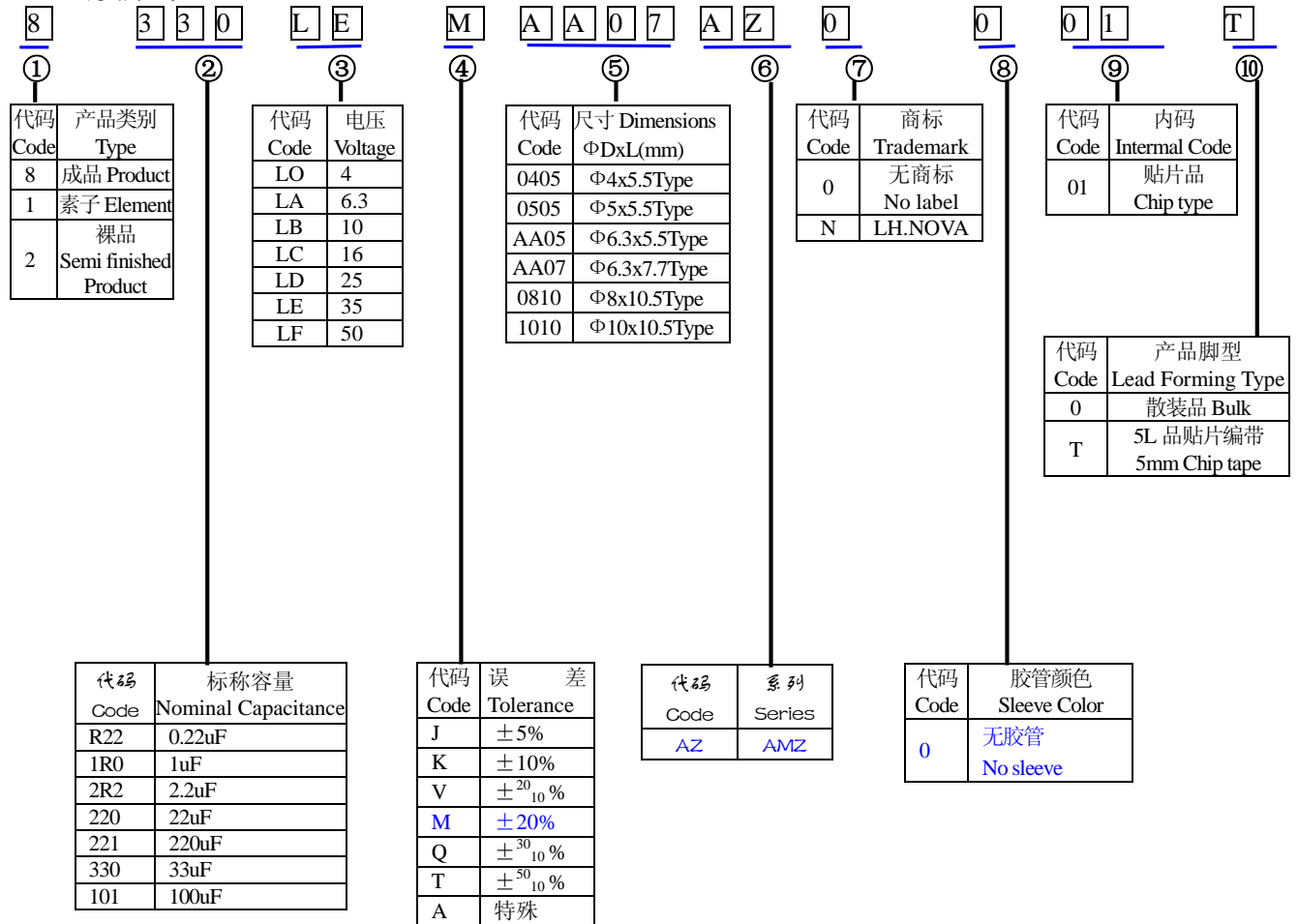



2.2 标记 MARKING

2.2.1 在电容器体上应注明如下内容 The following items shall be marked indelibly on the surface of capacitor:

- (1) 电容量 Capacitance.
- (2) 工作电压 Rated voltage.
- (3) 负极标志 Polarity of the terminals.
- (4) 系列代码 Series Code 示例 Sample: AMZ

系列代码
Series Code

2.2.2 标记颜色: 黑色

Marking color: Black

2.2.3 系列代码与印字代码对照表:

The relationship between the series and the code:

系列代码 series	印字代码 code
AMZ	AMZ

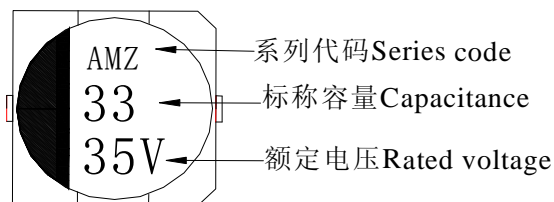

3. 主要特性表 MAIN SPECIFICATIONS

项目 Item	主要特性 Performance Characteristics						
额定工作电压范围 Rated Voltage Range	6.3~50V.DC						
使用温度范围 Operating Temperature Range	-55℃~+105℃						
标称静电容量范围 Nominal Capacitance Range	1~330 μ F						
静电容量允许偏差 Capacitance Tolerance	±20% (M, +20℃, 120Hz)						
漏电流 Leakage Current (20℃)	额定工作电压(V) Rated working voltage	6.3~50					
	漏电流 Leakage current	2 分钟后 I≤0.01CV 或 3(μ A),取最大值 After 2 min. I≤0.01CV or 3(μ A), Whichever is greater.					
C: 标称静电容量 (μ F) Nominal Capacitance in μ F V: 额定工作电压 (V) Rated working voltage in V							
损耗角正切 DF Dissipation Factor	额定工作电压(V) Rated working voltage	6.3	10	16	25	35~50	
	DF(MAX) (20℃,120Hz)	0.26(0.28)	0.20(0.24)	0.16(0.20)	0.14(0.16)	0.12(0.14)	
注: ()为 Φ8 以上产品。							
浪涌电压 Surge Voltage	额定工作电压(V) Rated working voltage	6.3	10	16	25	35	50
	浪涌电压 Surge voltage (V)	8	13	20	32	44	63
温度特性 Temperature Stability	额定工作电压(V) Rated working voltage						
		6.3	10	16	25	35~50	
	阻抗比(120Hz) Impedance Ratio	z-25℃/z+20℃		3	2	2	2
	z-40℃/z+20℃		5	4	4	3	3



项目 Item	主要特性 Performance Characteristics
高温负荷特性 Load life	<p>在+105℃ 环境中施加额定工作电压和最大允许纹波电流 2000 小时后,电容器的性能符合下面要求:</p> <p>After application of rated working voltage with max permissible ripple current specified at +105℃ for 2000 hours, capacitors meet the characteristics requirements measured at +20℃ listed at below:</p> <ol style="list-style-type: none">1、 电容量变化率:±30%初始测量值以内 Capacitance change : ±30% initial measured value2、 漏电流: ≤初始规定值 Leakage current: ≤initial specified value3、 损耗角正切值≤300%倍初始规定值 Dissipation factor: ≤300% initial specified value
高温贮存特性 Shelf life	<p>在+105℃环境无负荷放置 1000 小时后, 电容器的性能符合下面要求</p> <p>After leaving capacitors under no load at +105℃ for 1000 hours, capacitors meet the characteristics listed as below:</p> <ol style="list-style-type: none">1、 电容量变化率:±25%初始测量值以内 Capacitance change : ±25% initial measured value2、 漏电流: ≤200%初始规定值 Leakage current: ≤200% initial specified value3、 损耗角正切值≤200%倍初始规定值 Dissipation factor: ≤200% initial specified value
温度循环 Temperature cycling	<p>高温: 105℃, 负温: (6.3~50V) -55℃, 高低温下暴露时间: 各 30min;转换时间: ≤1min;</p> <p>循环次数: 1000 次; 试验结束后 24h±4h 内进行电性能测量符合下面要求:</p> <p>High temperature:+105℃. Low temperature: (6.3~50V) -55℃. Duration at each temperature:30min;Transition time: ≤ 1min. Severity:1000cycles. Measurement at 24 ± 4 hours after test conclusion, capacitors meet the characteristics listed as below.</p> <ol style="list-style-type: none">1、 电容量变化率:±20%初始测量值以内 Capacitance change : ±20% initial measured value2、 漏电流: ≤200%初始规定值 Leakage current: ≤200% initial specified value3、 损耗角正切值≤200%倍初始规定值 Dissipation factor: ≤200% initial specified value



<p>高温高湿 Biased humidity</p>	<p>在 85℃,湿度为 85%, 无直流电的环境中放置 1000 小时后,电容器的性能符合以下的要求: The specifications shall be satisfied when the capacitors are restored to 20℃ after subjecting them to store at 85℃,85% RH for 1000 hours, without DC applied.</p> <table border="1" data-bbox="448 394 1434 723"> <tr> <td>外观 Appearance</td> <td>没有明显变化 No significant damage</td> </tr> <tr> <td>容量变化 Capacitance Charge</td> <td>小于初始值的±20% ≤±20% of the initial specified value</td> </tr> <tr> <td>损失 DF</td> <td>小于初始规定值的 150% ≤150% of the initial specified value</td> </tr> <tr> <td>阻抗 ESR</td> <td>小于初始规定值的 150% ≤150% of the initial specified value</td> </tr> <tr> <td>漏电流 Leakage current</td> <td>小于初始规定值的 200% ≤200% of the initial specified value</td> </tr> </table>	外观 Appearance	没有明显变化 No significant damage	容量变化 Capacitance Charge	小于初始值的±20% ≤±20% of the initial specified value	损失 DF	小于初始规定值的 150% ≤150% of the initial specified value	阻抗 ESR	小于初始规定值的 150% ≤150% of the initial specified value	漏电流 Leakage current	小于初始规定值的 200% ≤200% of the initial specified value
外观 Appearance	没有明显变化 No significant damage										
容量变化 Capacitance Charge	小于初始值的±20% ≤±20% of the initial specified value										
损失 DF	小于初始规定值的 150% ≤150% of the initial specified value										
阻抗 ESR	小于初始规定值的 150% ≤150% of the initial specified value										
漏电流 Leakage current	小于初始规定值的 200% ≤200% of the initial specified value										
<p>耐溶剂性 Resistance to solvents</p>	<p>三种溶剂: 溶剂 a)在 20℃~30℃按下述配方构成混合溶剂: 1) 一份体积的分析纯异丙醇; 2) 三份体积的 80%体积的煤油和 20%体积的乙苯构成的混合液; 溶液 b)三氯三氟乙烷, 半水溶性的溶剂; 溶剂 c)在 63℃~70℃, 按下述配方构成混合溶剂: 1) 42 份体积的去离子水; 2) 一份体积的乙二醇-丁醚; 3) 一份体积的单乙醇胺; 将样品分成 3 组, 分别浸在 a、b、c 三种溶剂 3min 后擦拭 10 次; 擦拭后, 立即按上述方法再重复 2 回, 浸、刷共 3 回。然后用水洗清洗剂进行清洗, 并在室温下对整个表面进行通风干燥。电容器的性能符合下面要求: The solvent solutions used in this test shall consist of the following. a. A mixture consisting of the following : 1. One part by volume of isopropyl alcohol. 2. Three by volume of mineral spirits in accordance with MIL-PRF-680,type 1,or three parts by volume of a mixture of 81percent by volume of kerosene and 20 percent by volume ethyl benzene. The solution shall be maintained at a temperature of 25℃ ± 5℃. b. Trichlorotrifluoroethane , semi-water soluble solvents. c. A mixture consisting of the following . 1.Forty-two parts by volume water ,1 me ohm-cm minimum resistively, 2.One part by volume of propylene glycol monomethyl ether(glycol ether PM,1-methoxy-2-propanol). 3.One part by volume of monoethanolamine . The solution shall be maintained at a temperature of 63℃to70℃. The specimens subjected to this test shall be divided into three groups of approximately equal size, were immersed in a, b, c three solvents solutions. The specimens shall be completely immersed for 3 minutes, immediately following immersing, each specimen shall be tested as follows: The bristle portion of the brush, shall be dipped in the solution until wetted and the specimen shall be brushed with normal hand pressure (approximately 2 to 3 ounce applied normal to the surface) for ten strokes on the portion of the specimen where has been applied. The brush stroke shall be directed in a forward direction across the surface of the specimen being tested . immediately after brushing , the procedure shall be repeated two more times , for a total of three immersions, followed by brushing. After completion of the third immersion and brushing, the specimens shall be rinsed in approximately 25℃ water and all surfaces sir-blown dry. capacitors meet the characteristics listed as below. 1、电容量变化率:±3%初始测量值以内 Capacitance change : ±3% initial measured value 2、漏电流: ≤初始规定值 Leakage current: ≤initial specified value 3、损耗角正切值≤初始规定值 Dissipation factor: ≤initial specified value</p>										



<p>机械冲击 Mechanical shock</p>	<p>正半弦波; 峰值加速度: 100g ;脉冲持续时间: 6ms; 三轴六向各 3 次, 共 18 次, 电容器的性能符合下面要求: Half-sine ,Peak value:100g, Normal duration;6ms Three shocks in each direction shall be applied along the three mutually perpendicular axes of the test specimen(18 shocks) capacitors meet the characteristics listed as below.</p> <ol style="list-style-type: none">1、电容量变化率:±3%初始测量值以内 Capacitance change : ±3% initial measured value2、漏电流: ≤初始规定值 Leakage current:≤initial specified value3、损耗角正切值≤初始规定值 Dissipation factor: ≤initial specified value
<p>振动 Vibration</p>	<p>频率: 10Hz~2000Hz; 加速度: 5g ;一个循环 20min;X、Y、Z 三个方向每个方向 12 个循环, 共 36 个循环, 电容器的性能符合下面要求: The entire frequency range of 10 to 2000 Hz and return to 10Hz shall be traversed in 20 minutes. this cycle shall be performed 12 times in each of three mutually perpendicular directions (total of 36 times),so that the motion shall be applied for a total period of approximately 12 hours. peak value:5g. capacitors meet the characteristics listed as below.</p> <ol style="list-style-type: none">1、电容量变化率:±3%初始测量值以内 Capacitance change : ±3% initial measured value2、漏电流: ≤初始规定值 Leakage current:≤initial specified value3、损耗角正切值≤初始规定值 Dissipation factor: ≤initial specified value
<p>耐焊接热试验 Test of resistance to soldering heat</p>	<p>电容引脚向下放置在一块金属板上, 在 260℃下放置 10 秒, 取出后放置于空气中到达室温, 测试性能符合下表要求。 Capacitors placed on a 260℃ hot plat for 10 seconds with their electrode terminals facing downward will fulfill following conditions after being cooled to room temperature.</p> <ol style="list-style-type: none">1、电容量变化率:±10%初始测量值以内 Capacitance change : ±10% initial measured value2、漏电流: ≤初始规定值 Leakage current:≤initial specified value3、损耗角正切值≤初始规定值 Dissipation factor: ≤initial specified value
<p>静电放电 ESD</p>	<p>接触放电; 放电电压: 500V; 每个样品每个电极承受两次放电, 正、负极性各 1 次, 电容器的性能符合下面要求: Direct contact discharge ,indicated voltage :500v;Two discharges shall be applied to each PUT within a sample group and at each stress voltage level, one with a positive polarity and one with a negative polarity. capacitors meet the characteristics listed as below.</p> <ol style="list-style-type: none">1、电容量变化率:±3%初始测量值以内 Capacitance change : ±3% initial measured value2、漏电流: ≤初始规定值 Leakage current:≤initial specified value3、损耗角正切值≤初始规定值 Dissipation factor: ≤initial specified value



<p>可焊性 solderability</p>	<p>焊料(Solder) : H60A. H60S or(或)H63A 焊接温度(Solder temperature) : 245±2℃ 浸入时间(Immersion time) : 3±0.5sec(秒) 浸入深度(Immersion depth) : 2mm 熔化: 松香在酒精的浓度是 25% Flux: 25% by weight of rosin in ethanol 从含浸处到顶部, 至少要有 3/4 的部分覆盖有新焊料 SPEC:1)3/4 of the circumference of the surface up to the immersed shall be covered with new solder.</p>																		
<p>可燃性 (对绝缘底座进行 试验) Flammability</p>	<p>样品置于纸包松木板上方 200mm 处, 用 12mm 针焰, 每一试样引燃 3 次, 分别引燃 10s、60s、120s。 Test is applicable to components having a resin case. The test flame is applied for 10s.If a self-sustaining flame does not last longer than 15 s ,the test flame is applied again for 1 min at the same point or any other point .If again a self-sustaining flame does not last longer than 15 s ,the test flame is then applied for 2 min at the same point or any other point . 要求: 第一次施加试验火焰后, 试样不应完全燃尽, 任一次施加试验火焰后, 任何试样的燃烧持续时间应≤15g, 薄垫纸应不被引燃, 松木板应不被烤焦炭化。 Requirement; After the first application of the test flame, the test specimens shall not be consumed completely. After any application of the test flame, the duration of the burning of any specimen shall not exceed 15s, while the average burning time shall not exceed 10s .The tissue paper shall not ignite and the board shall not scorch.</p>																		
<p>浪涌电压 Surge Voltage</p>	<p>在常温下, 串联电阻为 1K Ω 的环境下使用最大浪涌电压充电 30 秒和在不充电情况下放电 1 分钟 30 秒, 循环 1000 次, 电容器的性能符合以下要求: The capacitors shall be subjected to 1000 cycle each consisting of charge with the surge voltages specified at 105℃ for 30 seconds through a protective resistor (R=1K Ω) and discharge for 5 minutes 30 seconds.</p> <table border="1" data-bbox="448 1240 1461 1568"> <tr> <td>外观 Appearance</td> <td>没有明显变化 No significant damage</td> </tr> <tr> <td>容量变化 Capacitance Charge</td> <td>小于初始值的±20% ≤±20% of the initial specified value</td> </tr> <tr> <td>损失 DF</td> <td>小于初始规定值的 150% ≤±150% of the initial specified value</td> </tr> <tr> <td>阻抗 ESR</td> <td>小于初始规定值的 150% ≤±150% of the initial specified value</td> </tr> <tr> <td>漏电流 Leakage current</td> <td>小于初始规定值 ≤the initial specified value</td> </tr> </table>	外观 Appearance	没有明显变化 No significant damage	容量变化 Capacitance Charge	小于初始值的±20% ≤±20% of the initial specified value	损失 DF	小于初始规定值的 150% ≤±150% of the initial specified value	阻抗 ESR	小于初始规定值的 150% ≤±150% of the initial specified value	漏电流 Leakage current	小于初始规定值 ≤the initial specified value								
外观 Appearance	没有明显变化 No significant damage																		
容量变化 Capacitance Charge	小于初始值的±20% ≤±20% of the initial specified value																		
损失 DF	小于初始规定值的 150% ≤±150% of the initial specified value																		
阻抗 ESR	小于初始规定值的 150% ≤±150% of the initial specified value																		
漏电流 Leakage current	小于初始规定值 ≤the initial specified value																		
<p>端子强度 Terminal strength</p>	<p>1) 拉力(tensile)</p> <table border="1" data-bbox="448 1615 1433 1789"> <thead> <tr> <th>d(mm)</th> <th>[N]</th> <th>Duration time</th> </tr> </thead> <tbody> <tr> <td>0.3<d≤0.5</td> <td>5</td> <td rowspan="3">10±2sec(秒)</td> </tr> <tr> <td>0.5<d≤0.8</td> <td>10</td> </tr> <tr> <td>0.8<d≤1.25</td> <td>20</td> </tr> </tbody> </table> <p>2) 抗弯强度 (Bending) 端子应该在每一方向上折弯一次, 总共两次 The terminal shall be subjected to 1 bend in each direction to give a total 2 bends.</p> <table border="1" data-bbox="448 1888 1433 2063"> <thead> <tr> <th>d(mm)</th> <th>[N]</th> </tr> </thead> <tbody> <tr> <td>0.3<d≤0.5</td> <td>2.5 (0.25KG)</td> </tr> <tr> <td>0.5<d≤0.8</td> <td>5.0 (0.51KG)</td> </tr> <tr> <td>0.8<d≤1.25</td> <td>10.0(1.0KG)</td> </tr> </tbody> </table> <p>端子没有破损或松动 SPEC: No breaking and loosening of terminal</p>	d(mm)	[N]	Duration time	0.3<d≤0.5	5	10±2sec(秒)	0.5<d≤0.8	10	0.8<d≤1.25	20	d(mm)	[N]	0.3<d≤0.5	2.5 (0.25KG)	0.5<d≤0.8	5.0 (0.51KG)	0.8<d≤1.25	10.0(1.0KG)
d(mm)	[N]	Duration time																	
0.3<d≤0.5	5	10±2sec(秒)																	
0.5<d≤0.8	10																		
0.8<d≤1.25	20																		
d(mm)	[N]																		
0.3<d≤0.5	2.5 (0.25KG)																		
0.5<d≤0.8	5.0 (0.51KG)																		
0.8<d≤1.25	10.0(1.0KG)																		



4. 外形尺寸 SHAPE AND DIMENSIONS (mm)

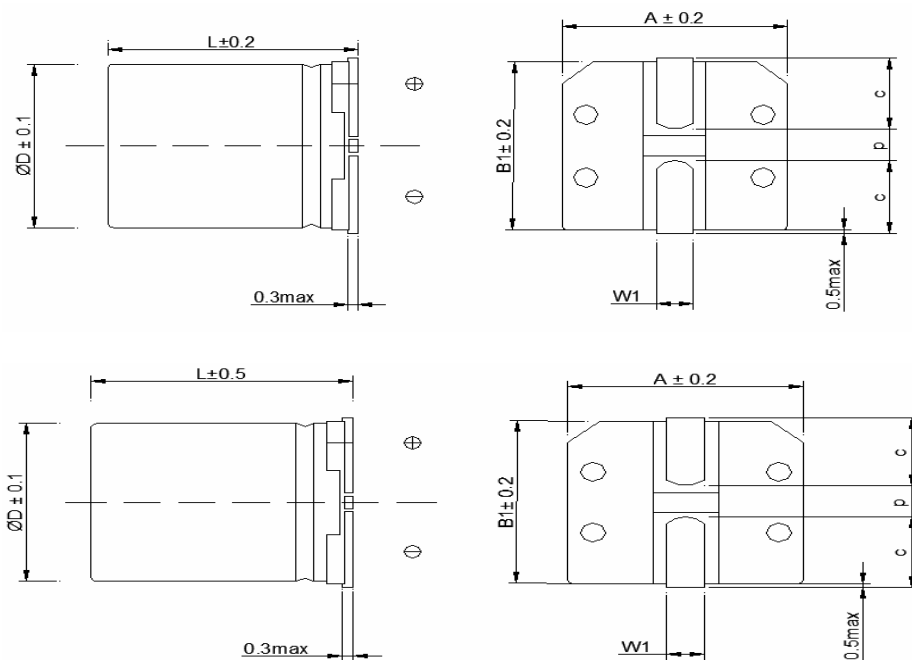

注：L=5.5mm L±0.2；L=7.7mm L±0.3；L=10.5-12.5mm L±0.5

φD	L	A	B ₁	C	W ₁	P±0.2
4	5.5	4.3	4.3	1.8	0.5~0.8	1.0
5	5.5	5.3	5.3	2.1	0.5~0.8	1.4
6.3	5.5	6.6	6.6	2.5	0.5~0.8	2.0
6.3	7.7	6.6	6.6	2.5	0.5~0.8	2.0
8	10.5	8.5	8.5	2.9	0.8-1.1	3.1
10	10.5	10.3	10.3	3.2	0.8~1.1	4.5

4. 1 回流焊温度曲线 REFLOW SOLDERING CURVE OF TEMPERATURE

4. 1. 1 电容表面温度不超过 260℃

Temperature at surface of capacitor shall not exceed 260℃.

4. 1. 2 电容表面温度超过 200℃ 的时间不超过 90 秒

Period that temperature at surface of capacitor becomes more than 200℃ shall not exceed 90 seconds.

4. 1. 3 预热温度不超过 200℃，时间不超过 180 秒

Preheat shall be made at maximum 200℃ and for maximum 180 seconds.

无铅回流焊温度曲线图 Graph for Lead-free reflow sold cringe temperature

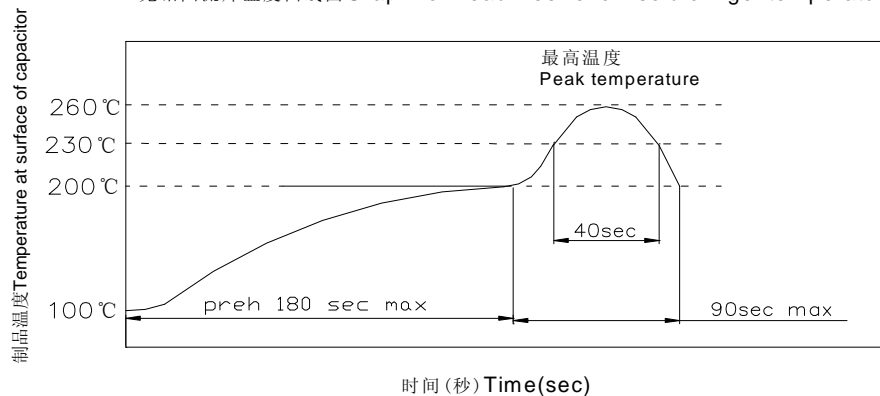



4. 1. 4 建议 PCB 焊盘设计标准 Recommended Land Pattern(mm)
Standard Termina

Case Dia	a	b	c
4	1.0	2.6	1.8
5	1.4	3.0	1.8
6.3	2.1	3.5	1.8
8	2.8	4.1	2.1
10	4.3	4.4	2.5

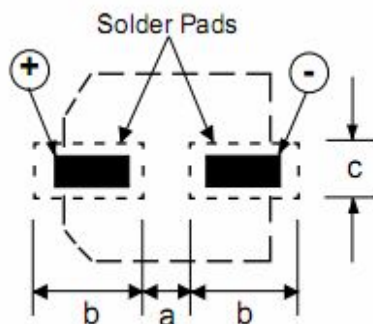

4. 2 编带 TAPING METHOD (mm)

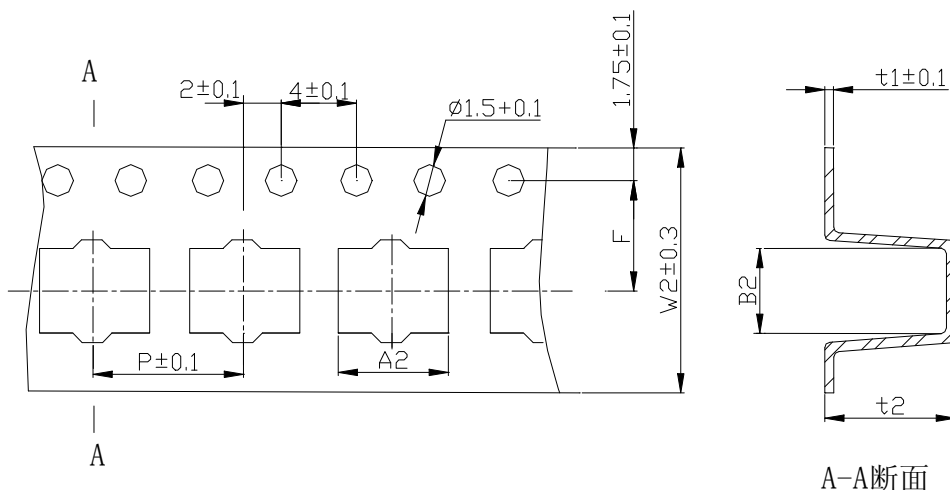

系列 Series	尺寸 Size	W ₂	A ₂	B ₂	P	t ₂	F	t ₁
AMZ	φ4×5.5	12.0	4.7	4.7	8	5.7	5.5	0.4
	φ5×5.5	12.0	5.7	5.7	12	5.7	5.5	0.4
	φ6.3×5.5	16.0	7.0	7.0	12	5.7	7.5	0.4
	φ6.3×7.7	16.0	7.0	7.0	12	8.3	7.5	0.4
	φ8×10.5	24	8.7	8.7	16	11	11.5	0.4
	φ10×10.5	24.0	10.7	10.7	16	11.0	11.5	0.4

5. 纹波电流频率因子 RIPPLE CURRENT FREQUENCY COEFFICIENT

Frequency coefficient of ripple current

Frequency 频率	50HZ	120 HZ	300 HZ	1K HZ	≥10K HZ
Coefficient 系数	0.35	0.50	0.64	0.83	1.00



6. 尺寸表、允许纹波电流 DIMENSIONS AND RIPPLE CURRENT (AMZ)

Cap/ μ F	6.3 (LA)			10(LB)			16(LC)			25(LD)			35(LE)			50(LF)		
	(1)	(2)	(3)	(1)	(2)	(3)	(1)	(2)	(3)	(1)	(2)	(3)	(1)	(2)	(3)	(1)	(2)	(3)
1.0																4×5.5	5.00	30
2.2																4×5.5	5.00	30
3.3																4×5.5	5.00	30
4.7													4×5.5	1.80	80	5×5.5	1.52	85
10										4×5.5	2.80	80	5×5.5	0.76	150	6.3×5.5	1.88	165
15							4×5.5	1.80	80	5×5.5	0.76	150	5×5.5	0.76	150	6.3×5.5	1.88	165
22				4×5.5	1.80	80	5×5.5	1.00	150	5×5.5	1.00	150	5×5.5	1.00	150	6.3×5.5	1.88	165
27	4×5.5	1.80	80	5×5.5	1.80	150	5×5.5	1.50	150	6.3×5.5	1.00	230	6.3×5.5	1.00	230	6.3×7.7	0.88	185
33	5×5.5	0.76	150	5×5.5	0.76	150	6.3×5.5	0.44	230	6.3×5.5	1.50	230	6.3×5.5	1.38	230	6.3×7.7	1.38	185
47	5×5.5	1.60	150	6.3×5.5	1.60	230	6.3×5.5	1.60	230	6.3×5.5	1.50	230	6.3×5.5	1.50	230	6.3×7.7	1.50	185
56	5×5.5	1.50	150	6.3×5.5	1.50	230	6.3×5.5	1.50	230	6.3×5.5	1.50	230	6.3×7.7	1.50	280	8×10.5	1.00	300
68	6.3×5.5	1.50	230	6.3×5.5	1.50	230	6.3×5.5	1.50	230	6.3×5.5	1.50	230	6.3×7.7	1.10	280	8×10.5	1.10	300
100	6.3×5.5	1.10	230	6.3×5.5	0.95	230	6.3×5.5	1.10	230	6.3×7.7	1.10	280	8×10.5	0.90	450	8×10.5	0.75	300
150	6.3×5.5	0.95	230	6.3×5.5	0.95	230	6.3×7.7	0.88	280	8×10.5	0.88	450	8×10.5	0.88	450	10×10.5	0.88	670
220	6.3×5.5	0.75	230	6.3×7.7	0.75	280	6.3×7.7	0.75	280	8×10.5	0.75	450	8×10.5	0.75	450	10×10.5	0.75	670
330	6.3×7.7	0.68	280	8×10.5	0.68	450	8×10.5	0.68	450	8×10.5	0.55	450	10×10.5	0.55	670			
470	8×10.5	0.50	450	8×10.5	0.50	450	8×10.5	0.50	450	10×10.5	0.45	670						
680	8×10.5	0.45	450	10×10.5	0.45	670	10×10.5	0.40	670									
1000	8×10.5	0.35	450	10×10.5	0.35	670												
1500	10×10.5	0.30	670															

(1) 外形尺寸 Case Size D×L(mm)

(2) 100KHz 阻抗值 Impedance at 100KHz +20℃ (Ω)

(3) 最大允许纹波电流 Max allowable ripple current (mArms +105℃, 100KHz)

6.1 客户料号与风华物料对照表 the list of the Customer P/N and Fenghua P/N

客户 P / N	风华 P / N
--	8101LEM0810AZ0001T



7. 包装 PACKING

7.1 包装标签 PACKING LABEL



规格、尺寸 Specification and dimensions

批号的填写 LOT:

1	2	3	4	5	6	7	8	9	10	11	12	13	14
---	---	---	---	---	---	---	---	---	----	----	----	----	----

类别 年份 月份 日期 区别号
Sort Year Month Date Discriminate mark

流传单号码
Sequence number

7.2 编带产品按下图包装

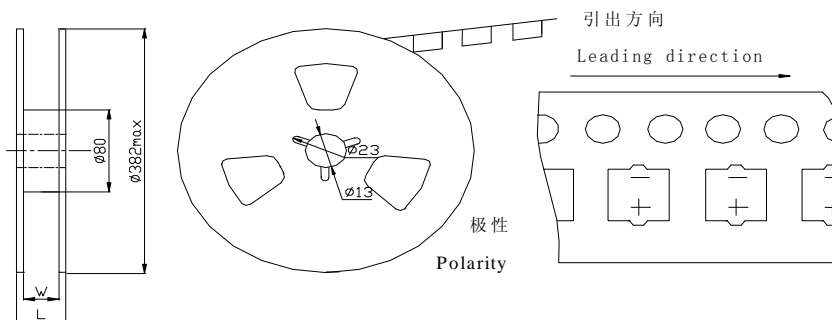

Taped capacitors are packed into carton, according to the following drawing.



垂直安装 Vertical Mount			
尺寸 Size	L	W ₃	数量 Quantity/reel
φ4×5.5	19	14	2000pcs
φ5×5.5	19	14	1000pcs
φ6.3×5.5	23	18	1000pcs
φ6.3×7.7	23	18	1000pcs
φ8×10.5	30	26	500pcs
φ10×10.5	28	26	500pcs



- 7.3 散装、编带品外包装箱不干胶标签，实用尺寸为 167.5mmX97.5mm。
The dimension of the label on the carton is 167.5mmX97.5mm

		广东风华高新科技股份有限公司 FENGHUA ADVANCED TECHNOLOGY HOLDING CO., LTD			
装箱清单号: LH201605140001			箱号: 12/42		
客户名称		业务员			
订单号: SA20160503002D 业务部: 业务四部			净重Kg: 2.4		毛重Kg: 4.8
序号	型号规格	客户料号	客户PO	数量 (只)	备注
1	8221LBMAA05MS0001T 220uF/10V φ6.3X5.5	EP98204881	622991	8	
合计				8	
品名PRODUCT: 片式铝电解电容 H. S Code号: 8532221000					
日期: 16/05/14					

8. 贮存方法 STORAGE METHODS

保存期限: 1年, 如果没有其他规定, 标准的测试、检验环境条件如下所示:

环境温度: 5至35℃; 相对湿度: 45至85%; 大气压力: 86kpa至106kpa。

如果对测试结果有异议, 可以在以下条件测试:

环境温度: 20±2℃; 相对湿度: 60至70%; 大气压力: 86kpa至106kpa。

Storage life: 1 year, Unless otherwise specified, the standard range of atmospheric conditions for making measurements and tests are as follows.

Ambient temperature: 5 to 35°C Relative humidity: 45 to 85% Air pressure: 86kpa to 106kpa.

If there may be doubt on the results, measurements shall be made within the following limits.

Ambient temperature: 20±2°C Relative humidity: 60 to 70% Air pressure: 86kpa to 106kpa.



9. 其它说明 OTHERS

9.1 铝电解电容器使用注意事项 Important information on the application of aluminium electrolytic capacitors

(1). 直流铝电解电容器应按正确的极性使用 DC electrolytic capacitors are polarized

当直流铝电解电容器被反极性接入电路时，电容器会导致电子线路短路，由此产生的电流会引致电容器损坏。若电路中有可能在负引线施加正极电压，请选用无极性产品。

When reverse voltage is applied on DC electrolytic capacitor, the capacitor will become short-circuited please use non-polarized capacitors in the circuit or the capacitor will be damage due to abnormal current flows through the capacitors since the circuit where the positive voltage may be applied to the cathode terminal.

(2). 在额定工作电压以下作用 Use capacitor within rated voltage

当电容器上所施加电压高于额定工作电压时，电容器的漏电流将上升，其电气特性将在短时期内劣化直至损坏。请注意电压峰值勿超出额定工作电压。

When capacitor is used at higher voltage than the rated voltage, leakage current increases, characteristics drastically deteriorate and damage in a short period may occur as a result. Please take extra caution that the peak voltage should not exceed the rated voltage.

(3). 作快速充放电使用 Charge and discharge application.

当常规电容器被用作快速充电用途。其使用寿命可能会因为容量下降，温度急剧上升等而缩减

When aluminum electrolytic capacitors for general purpose are employed in rapid charge and discharge application, its life may be shorted by capacitance decreasing, heat rising, etc.

(4). 电容器贮存 Store the capacitor.

当铝电解电容器作了长期贮存后，其漏电流通常升高，贮存温度愈高，漏电流上升愈快。因此应注意贮存环境的选择，在电容器上施加电压后，漏电流值将不断下降，在铝电解电容器的漏电流值上升对电路有不良影响的，请在使用前充电处理。

Increased leakage current is common in aluminum capacitors which have been stored for long period of time. The Higher the storage temperature, the higher the leakage current increase, therefore please take precautions concerning the storage location. The leakage current decreases gradually as voltage is applied to the capacitor. In cases where increased leakage current causes problems in the circuit, apply voltage (aging) before using.

(5). 施加纹波电流应小于额定值 Ripple current applied to capacitor should not exceed the rated value.

施加纹波电流超过额定值后，会导致电容器体过热，容量下降，寿命缩短。所施加纹波电压的峰值应小于额定工作电压。

Excessive heat will reduce capacitance and result in shortened life of capacitor if ripple currents exceeding the specified rated value are applied. The peak value of the ripple voltage should be less than the rated voltage.

(6). 使用环境温度 Ambient temperature.

铝电解电容器的使用寿命会受到环境温度的影响。据科学统计，使用环境温度下降 10℃ 其使用寿命增加 1 倍。

Its ambient temperature closely affects the life of an aluminum electrolytic capacitor. It is generally stated, that life doubles for each 10℃ decrease in temperature.

(7). 引出线强度 Lead stress

当拉力施加到电容器引出线，该拉力将作用于电容器内部，这将导致电容器内部短路，开路或漏电流上升。在电容器焊装到电路板，请勿强烈摇动电容器。

When a strong force is applied to the lead wires or terminals, stress is put on the internal connections. This may result in short circuit, open circuit or increased leakage current. It is not advisable to bend or handle a capacitor after it has been soldered to the PCB board.

(8). 焊接过程耐热性 Heat resistance at the soldering process

铝电解电容器装至电路板进行浸焊或波峰焊时，其塑料套管可能因焊接时间过长、温度过高而发生破裂或二次收缩。

In the dip soldering process of PCB board with aluminum electrolytic capacitors mounted, secondary shrinkage or crack of PVC sleeve may be observed when solder temperature is too high or dipping time is too long.

(9). 电路板的安装孔距及安装位置 Hole pitch and position of PCB board.

电路板安装孔的设计应与产品说明书的引线脚距相一致，如果将电容器强行插入孔距不配套的电路板，那么会有应力作用于引出线，这将导致短路或漏电流上升。

PCB board must be designed so its hole coincides with the lead pitch (lead spacing) of the capacitor specified by the catalog or specifications. When a capacitor is forcibly inserted into an unmatched hole, a stress is put on the leads. This could result in a short circuit or increased leakage current.

9.2 本产品不含铅、镉等元素 This product does not include Plumbum or Cadmium.